

TAPE-50/60/80

NASTRATURA INFERIORE
E SUPERIORE SCATOLA



ICMI
WISE PACKAGING

TAPE-50/60/80

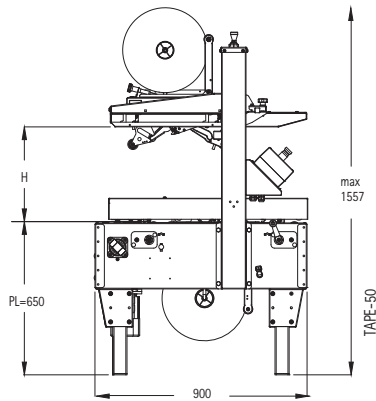
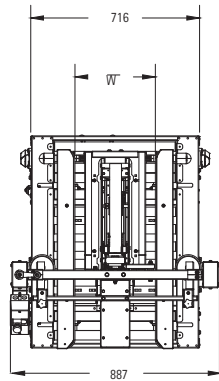

TAPE-50
Kg
112

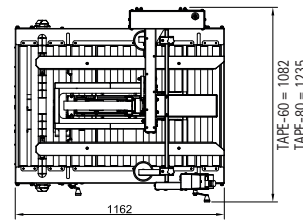
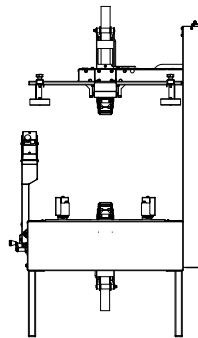
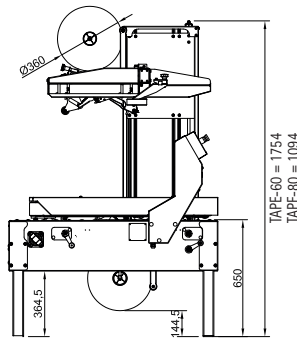

TAPE-60
Kg
168

TAPE-80
Kg
174

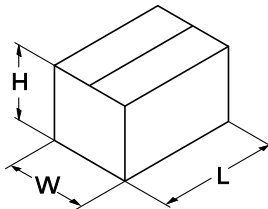

TAPE-50

	MIN	MAX
L	150 mm	800 mm
W	100 mm	500 mm
H	100 mm	500 mm

TAPE-60

	MIN	MAX
L	150 mm	∞
W	100 mm	670 mm
H	120 mm	670 mm

TAPE-80

	MIN	MAX
L	150 mm	∞
W	100 mm	820 mm
H	120 mm	820 mm

CARATTERISTICHE TECNICHE

- Cinghie di trascinamento: Laterali H=70 mm
- Regolazione dimensioni scatole: Manuale
- Teste : Superiore e Inferiore
- Configurazione standard: TAPE-50 T22, TAPE-60/80 T33
- Larghezza nastro: da 25 a 50 mm in funzione della Testa (da decidere in fase d'ordine)
- Tensione nastro: Regolabile
- Max diametro bobina nastro: 360 mm
- Diametro interno bobina: 76 mm
- Alimentazione elettrica: 380 V trifase - 50/60 Hertz
- Potenza installata: 0,25 Kw
- Protezione elettrica: IP 54
- Temperatura di esercizio: + 5° C - max. +35° C
- Velocità cinghie: 22 mt/min
- Produzione: 1000 scatole/h
- Altezza piano di lavoro: 650 mm
- Peso: TAPE-50 112 Kg, TAPE-60 168 Kg, TAPE-80 174 Kg
- Dimensioni Macchina (L x W x H): TAPE-50 900 x 887 x 1.560 mm, TAPE-60/80 1.162 x 1.082 x 1.754 mm

TECHNICAL FEATURES

- Drive belts: Side H=70 mm
- Carton size adjustment: Manual
- Heads: Upper and lower
- Standard configuration: TAPE-50 T22, TAPE-60/80 T33
- Tape width: from 25 to 50 mm depending on the head (to be indicated when ordering)
- Tape tension: Adjustable
- Max. tape reel diameter: 360 mm
- Internal reel diameter: 76 mm
- Power supply: 380 V three-phase - 50/60 Hertz
- Installed power: 0.25 kW
- Electrical protection: IP 54
- Working temperature: + 5° C - max. +35° C
- Belt speed: 22 m/min
- Production: 1000 cartons/h
- Working table height: 650 mm
- Weight: TAPE-50 112 Kg, TAPE-60 168 Kg, TAPE-80 174 Kg
- Machine dimensions (L x W x H) TAPE-50 900 x 887 x 1560 mm, TAPE-60/80 1162 x 1082 x 1754 mm

CARACTERISTIQUES TECHNIQUES

- Courroies d'entraînement : latérales h=70 mm
- Réglage des dimensions des boîtes : manuel
- Têtes : Supérieure et inférieure
- Configuration standard : TAPE-50 T22, TAPE-60/80 T33
- Largeur du ruban : de 25 à 50 mm selon la tête (à décider au moment de la commande)
- Tension du ruban : réglable
- Max diamètre de la bobine de ruban : 360 mm
- Diamètre intérieur de la bobine: 76 mm
- Alimentation électrique : 380 V triphasé - 50/60 Hertz
- Puissance installée : 0,25 kW*
- Protection électrique : IP 54
- Température de fonctionnement : + 5° C - max. +35° C
- Vitesse de rotation des courroies : 22 m/min
- Cadence de production : 1 000 boîtes/h
- Hauteur du plan de travail : 650 mm
- Poids : TAPE-50 112 kg, TAPE-60 168 kg, TAPE-80 174 kg
- Dimensions de la machine (Lxlxh) : TAPE -50 900 x 887 x 1 560 mm, TAPE-60/80 1 162 x 1 082 x 1 754 mm

TECHNISCHE DATEN

- Transportriemen: Seitlich H = 70 mm
- Einstellung auf Kartongrößen: Manuell
- Köpfe: Oben und unten
- Standardkonfiguration: TAPE-50 T22, TAPE-60/80 T33
- Klebebandbreite: zwischen 25 und 50 mm je nach installiertem Kopf (bei der Bestellung zu bestimmen)
- Bandspannung: Einstellbar
- Max. Durchmesser der Bandrolle: 360 mm
- Innendurchmesser der Rolle: 76 mm
- Stromversorgung: 380 V dreiphasig - 50/60 Hertz
- Installierte Leistung: 0,25 kW
- Schutzart: IP 54
- Betriebstemperatur: + 5° C - max. +35° C
- Riemengeschwindigkeit: 22 m/min
- Produktion: 1000 Kartons/Std.
- Arbeitstischhöhe: 650 mm
- Gewicht: TAPE-50 112 kg, TAPE-60 168 kg, TAPE-80 174 kg
- Maschinenmaße (L x B x H): TAPE-50 900 x 887 x 1.560 mm, TAPE-60/80 1.162 x 1.082 x 1.754 mm

CARACTERÍSTICAS TÉCNICAS

- Drive belts: Side H=70 mm
- Carton size adjustment: Manual
- Heads: Upper and lower
- Standard configuration: TAPE-50 T22, TAPE-60/80 T33
- Tape width: from 25 to 50 mm depending on the head (to be indicated when ordering)
- Tape tension: Adjustable
- Max. tape reel diameter: 360 mm
- Internal reel diameter: 76 mm
- Power supply: 380 V three-phase - 50/60 Hertz
- Installed power: 0.25 kW
- Electrical protection: IP 54
- Working temperature: + 5° C - max. +35° C
- Belt speed: 22 m/min
- Production: 1000 cartons/h
- Working table height: 650 mm
- Weight: TAPE-50 112 Kg, TAPE-60 168 Kg, TAPE-80 174 Kg
- Machine dimensions (L x W x H) TAPE-50 900 x 887 x 1560 mm, TAPE-60/80 1162 x 1082 x 1754 mm

Es_ Las indicaciones presentadas no nos comprometen. De_ Die Angaben sind unverbindlich. Fr_ Les indications fournies ne sont pas contraignantes. En_ The information given is not binding. It_ Le indicazioni riportate non sono impegnative.



Verdellino BG Via Praga, 4
CAP 24040 loc. Zingonia (Italy)

Tel. +39 035-883450
www.icmi.it - icmi@icmi.it

